

# 회사 소개

**KohanKogyo**  
Technology for Your Business

## 한국고한고교주식회사

부산시 강서구 유통단지1로41  
부산T-PLEX 132동115,215호  
TEL ; 051-710-6342

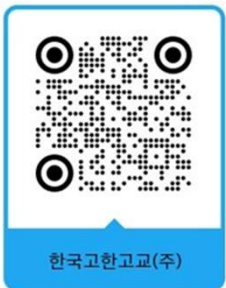

# 회사개요

KOHAN KOGYO는, 일본 동양제관(TOYO SEIKAN) Holdings의 그룹사  
일본국내 79사, 해외 32사 종업원 18,830명(2025년3월)

## 동양제관HDL

캔, PET병, 레토르트 포장材

2012년 설립, 동경1부 상장

연결매출 ; 9,225억엔 (2025년3월결산)



## 동양강판(주)

캔용 소재, 라미네이트 강판 등의 단압 MAKER

종업원 ; 1,515명 (2025년3월)

매출액 ; 1,284억엔(2024년3월)

## 고한고교(주)

설립 : 1934年

년간매출 : 191억엔 (2024年3월실적)

종업원 ; 620명(2025년3월)

지분 ; 동양강판(주) 100%



## 한국고한고교(주)

2012년 설립

자본금 7.8억원

지분 ; 고한고교(주) 100%

# 사업 내용

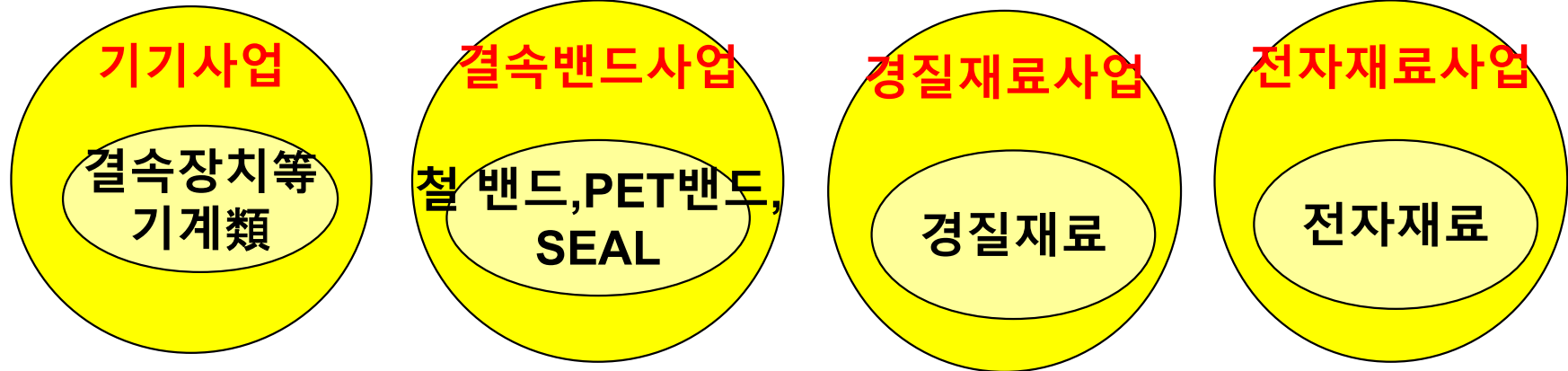

## 기업이념

우리는 항상時代의 NEEDS를 파악하여,  
독자적인 기술력으로 세계 산업계의 발전에 공헌한다.

## 기업 슬로건

지혜를 기술로, 기술로 SUPPORT  
합니다.

# Products MAP

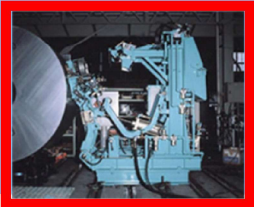
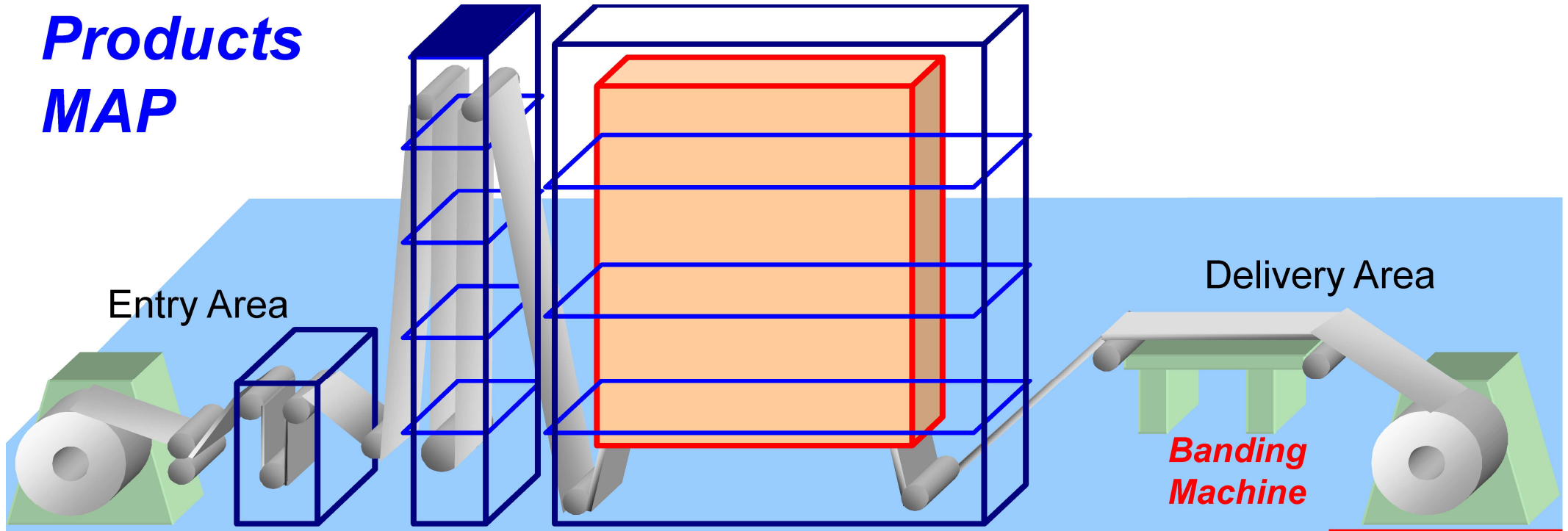

*Band Cutter*

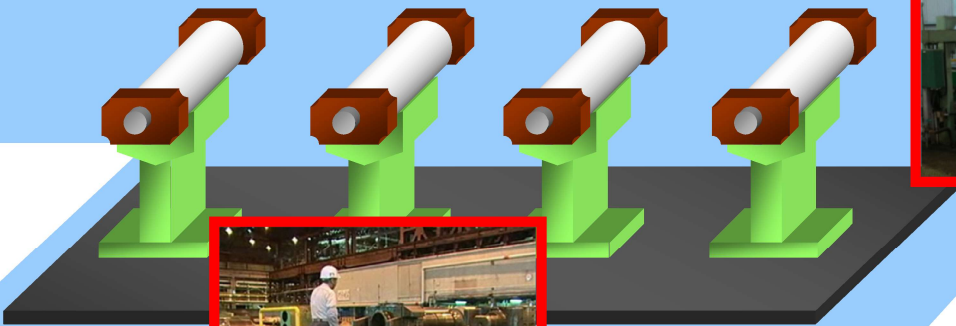
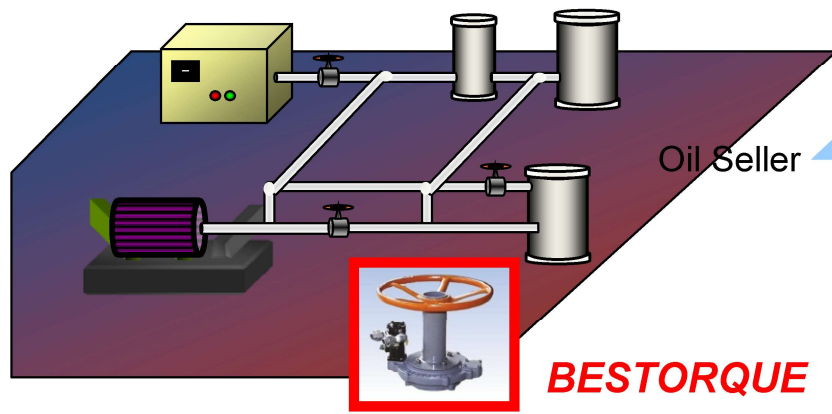

*Best Chocks  
Remover*

Roll Shop

# 제품LINE-UP

## 1. 자동결속기

일본 국내 점유율 No.1, 전 세계에 2000대를 넘는 판매실적.  
높은 신뢰를 받고 있습니다.

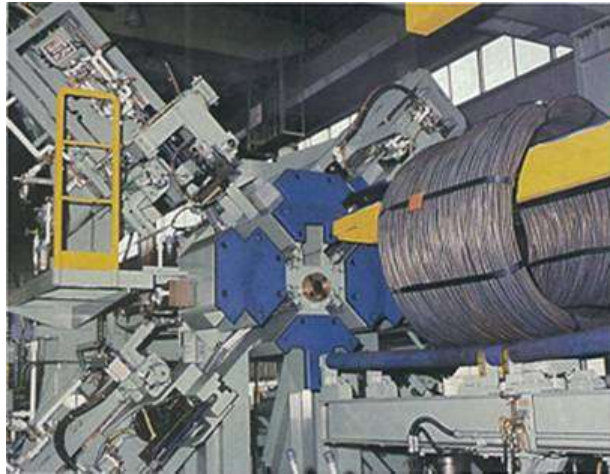

W/ROD 결속

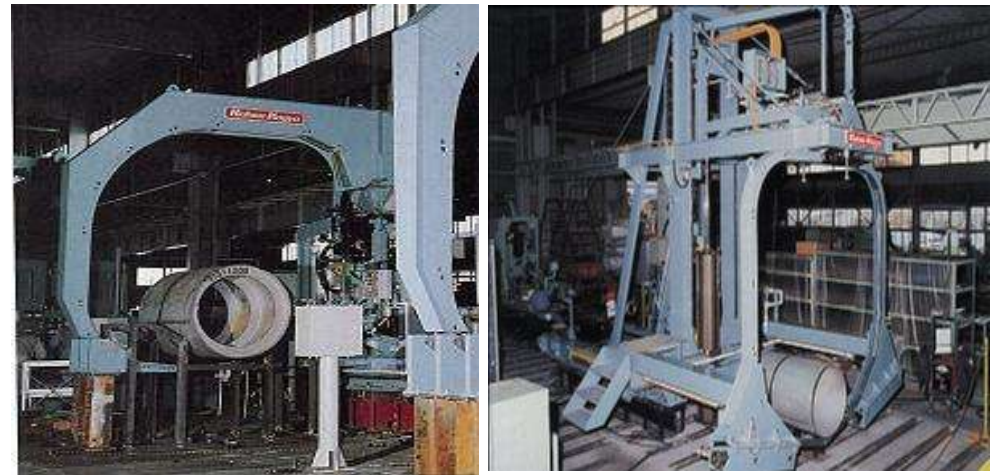

COIL 외주 결속

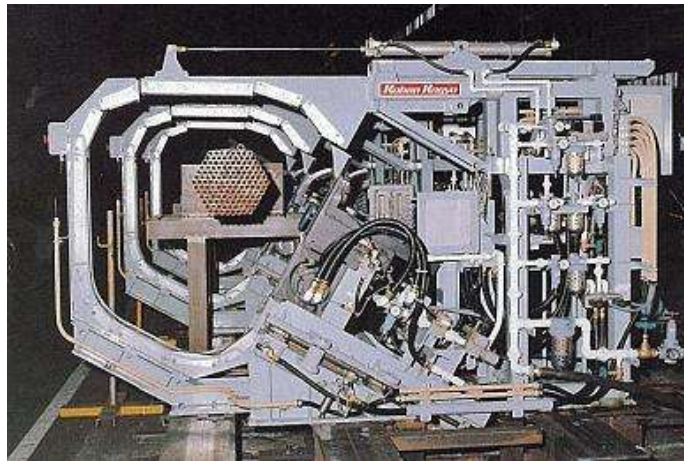

PIPE 결속



COIL EYE BAND 결속

판재결속 등 모든 철강 제품 및 비철금속 제품에 대응.

## 2. 결속HEAD

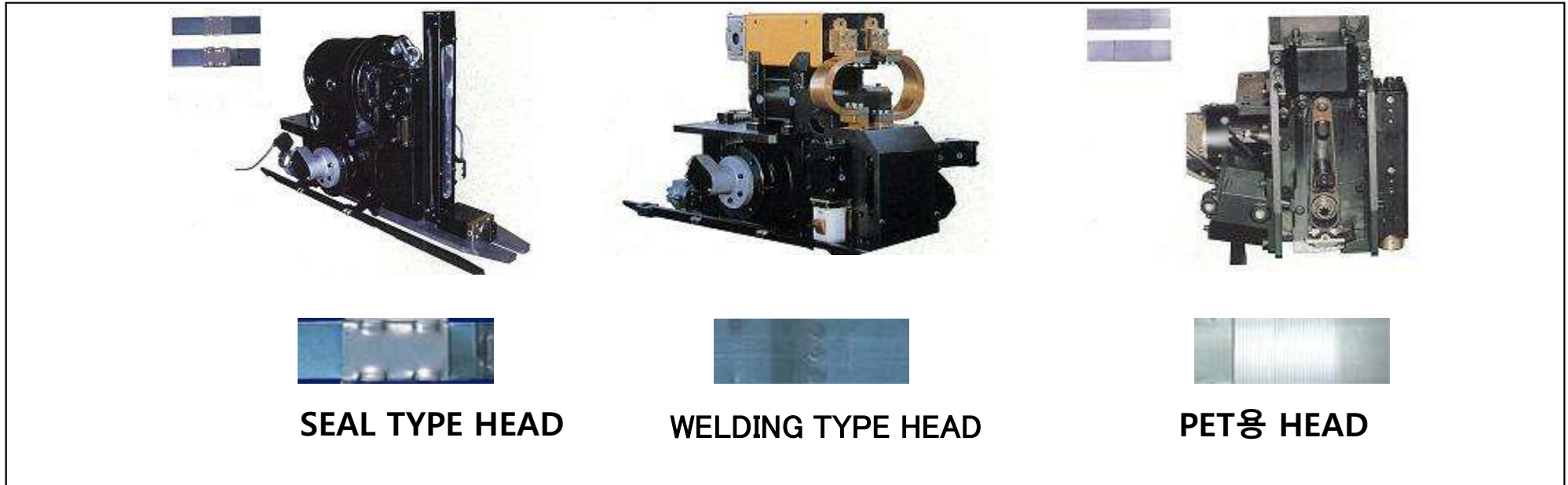

## 3. 자동 밴드CUTTER

: 압연공정 입측부에 설치하는 밴드 자동 절단기. 廢밴드의 권취기능 추가로 Scrap처리 용이.



## 4. Dispenser

### ① Air구동

; 고온 환경 안정가동

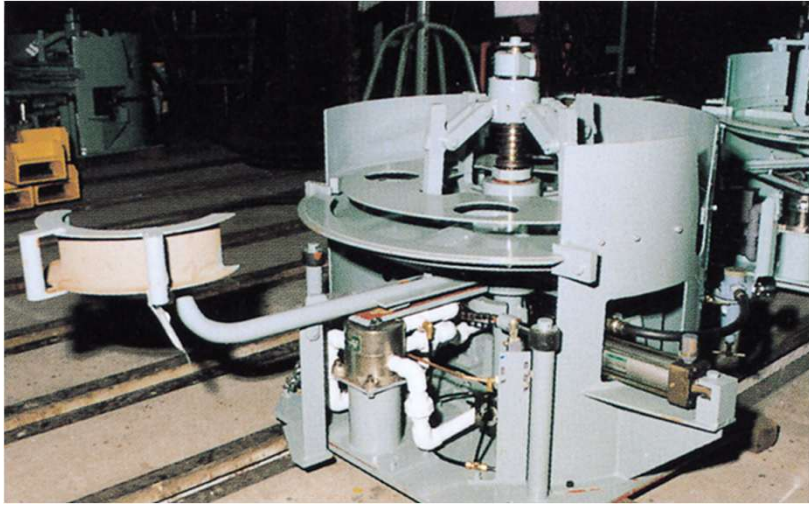

### ② 전동구동 (협력사 제작)

; Single / 2-In-1 Type



# 5. Air구동형 Hand Tool 제품

## Basic Tool



HP : Tightener                      S : Sealer

경량으로, 콤팩트하면서도 고강도  
결속 가능한 BASIC TOOL

## Combination Tool



MPL : 소형포장용                      MPH : 중량포장용



MV : PET BAND용



Hoop Cutter with Air Hammer



Hoop Cutter CA-32

## 6. 자동결속기/Band Cutter/Tool用 Air Motor및 부품



## 6. Air Motor Valve Actuator

; 일본 국내 석유 플랜트 중심으로 2만대 판매실적 보유



**BESTORQUE**  
설치 대상



원격지역

효율화  
집중관리



위험  
피해확대

고부하



수동조작

省力化

안전대책  
긴급차단



위험구역  
긴급사태

## Bestorque Merit

1. Valve설치비용 저렴.
2. 구조 간단하고 Compact.
3. All-Air 구조로 완전방폭형.
4. 폭 넓은 Torque와 회전수.
5. 원격조작 가능.

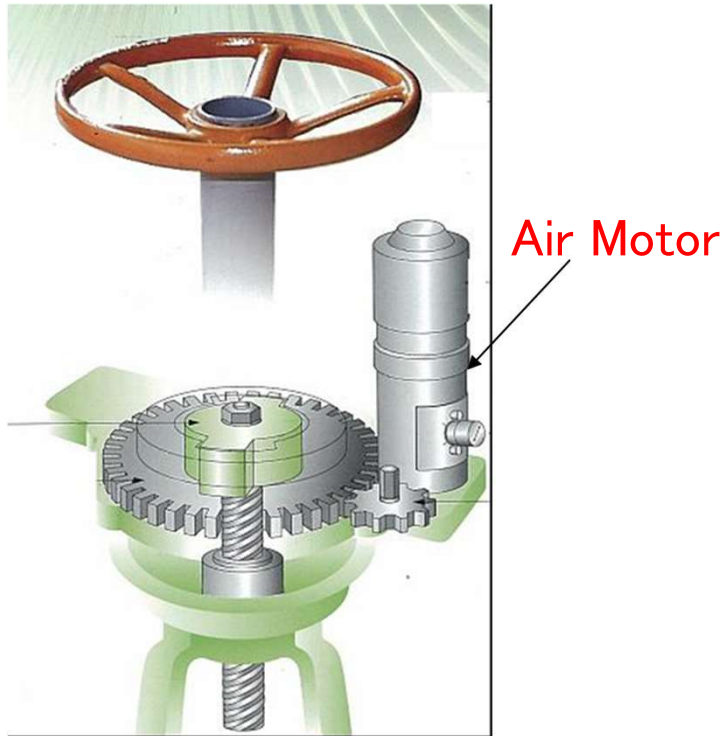

### ※ 설치 가능 Valve

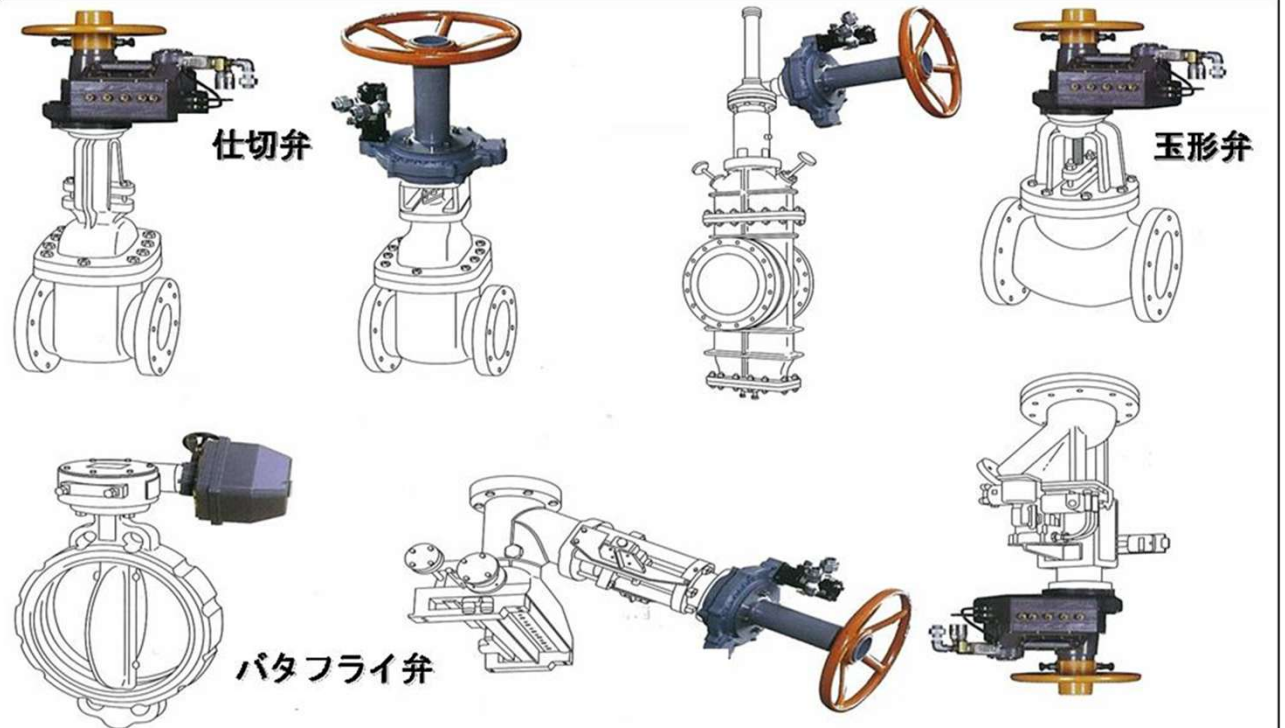

## 8. Air Bearing

; 중량물 운송용 공기부양 운송 시스템

바닥면 사진



제트 엔진 조립공정 적용사례



COIL이송적용사례



발전소 用 열교환기 이동 적용사례



# 9. 기타 제품 Line-Up

## ① 결속BAND제품

제 품	사 양	용 도														
 <p><b>STEEL BAND</b> 「SS-TOP」</p>	<table border="1"> <thead> <tr> <th colspan="2">사 양</th> </tr> </thead> <tbody> <tr> <td>두께</td> <td>0.5, 0.6, 0.7, 0.8, 0.9, 1.0, 1.2mm</td> </tr> <tr> <td>폭</td> <td>16, 19, 25, 32mm</td> </tr> <tr> <td>인장강도</td> <td>56 ~ 120kg/mm<sup>2</sup></td> </tr> <tr> <td>연신율</td> <td>2 ~ 8%</td> </tr> <tr> <td>권취형상</td> <td>리본 권취(수작업용) 오실레이션 권취(자동결속용)</td> </tr> <tr> <td>표면처리</td> <td>BLUEING, BLUEING無처리, 칼라, 도금</td> </tr> </tbody> </table>	사 양		두께	0.5, 0.6, 0.7, 0.8, 0.9, 1.0, 1.2mm	폭	16, 19, 25, 32mm	인장강도	56 ~ 120kg/mm <sup>2</sup>	연신율	2 ~ 8%	권취형상	리본 권취(수작업용) 오실레이션 권취(자동결속용)	표면처리	BLUEING, BLUEING無처리, 칼라, 도금	<p>1) 철강제품 결속 2) 동,알루미늄의 비철금속결속 3) 廢플라스틱등 재활용품 결속</p> <p><b>【관련상품】</b></p> <div style="display: flex; justify-content: space-around;"> <div data-bbox="1525 563 1787 715"> <p>オーバーラップシール Overlap Seal</p>  </div> <div data-bbox="1800 563 2063 715"> <p>ラッシングシール Lashing Seal</p>  </div> </div> <div style="display: flex; justify-content: space-around; margin-top: 10px;">   </div>
사 양																
두께	0.5, 0.6, 0.7, 0.8, 0.9, 1.0, 1.2mm															
폭	16, 19, 25, 32mm															
인장강도	56 ~ 120kg/mm <sup>2</sup>															
연신율	2 ~ 8%															
권취형상	리본 권취(수작업용) 오실레이션 권취(자동결속용)															
표면처리	BLUEING, BLUEING無처리, 칼라, 도금															
 <p><b>PET BAND</b> 「Ester-top」</p>	<table border="1"> <thead> <tr> <th colspan="2">사 양</th> </tr> </thead> <tbody> <tr> <td>두께</td> <td>0.5, 0.6, 0.8, 1.0, 1.2mm</td> </tr> <tr> <td>폭</td> <td>16, 19, 25, 32mm</td> </tr> <tr> <td>인장강도</td> <td>350 ~ 1,050kg</td> </tr> <tr> <td>권취형상</td> <td>오실레이션권취</td> </tr> <tr> <td>색</td> <td>흰색, 녹색, 회색, 검정색</td> </tr> </tbody> </table>	사 양		두께	0.5, 0.6, 0.8, 1.0, 1.2mm	폭	16, 19, 25, 32mm	인장강도	350 ~ 1,050kg	권취형상	오실레이션권취	색	흰색, 녹색, 회색, 검정색	<p>1) 종이·펄프 2) 섬유 3) PET병</p>		
사 양																
두께	0.5, 0.6, 0.8, 1.0, 1.2mm															
폭	16, 19, 25, 32mm															
인장강도	350 ~ 1,050kg															
권취형상	오실레이션권취															
색	흰색, 녹색, 회색, 검정색															

## ② KH 경질재료<참고>

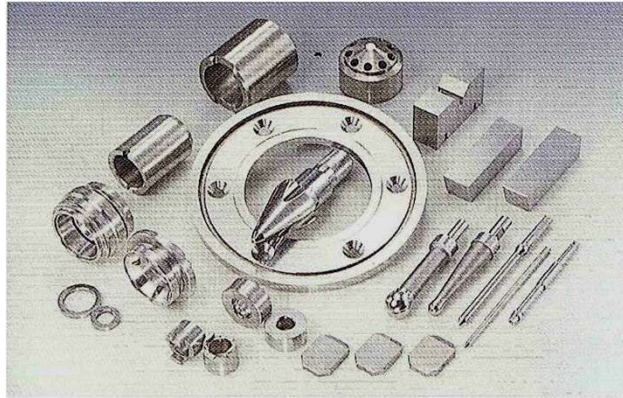

各種機械部品

Miscellaneous mechanical parts



樹脂成形機用部品

Parts of injection molding machine

## ③ HARD DISC <참고>



ハードディスク用基板  
Hard disk - base plate

고한고교의 제품은, 세계 30여국에 판매 중.



한국을 포함해 중국 제작/판매 판매 거점 보유.